



AQ-RO-3

Under Sink Water Filter

# **OptimH2O<sup>®</sup> Reverse Osmosis + Claryum<sup>®</sup>**

Owner's Manual

## REQUIRED TOOLS & MATERIALS

- Basic plumbing knowledge
- Tape Measure
- Utility Knife
- Screwdriver (Phillips)
- $\frac{1}{8}$ " &  $\frac{1}{32}$ " Drill Bits/Drill
- Adjustable Wrench
- Bleach
- Safety Glasses
- Pencil
- Masking Tape
- Pan or Bucket



## WHAT'S INCLUDED

- |   |                               |                                |
|---|-------------------------------|--------------------------------|
| A System Manifold   | H Water Storage Tank          | P Tubing $\frac{1}{4}$ " White |
| B Carbon Filter Sump  | I Eye Dropper                 | Q Tubing $\frac{3}{8}$ " White |
| C Membrane Filter Sump                                      | J Tank Connector              | R Tubing $\frac{3}{8}$ " Red   |
| D Claryum Filter Sump                                       | K Plumber's Tape              | S Screws + Bracket             |
| E Remineralizer   | L Drain Connector             | T Brass Tee                    |
| F Faucet  | M Nuts & Bolts                | U Carbon Filter Cartridge      |
| G Gasket, Nut, Washer, Spacer, Quick Connector (for faucet) | N Foam Seal                   | V Claryum Filter Cartridge     |
|   | O Flow Restrictor & 90° Elbow |                                |



## 1 — INSTALL BRASS TEE FITTING

- 1 Turn off the cold water supply to the sink.
- 2 Turn on the kitchen faucet to release pressure and allow water to drain from the line.
- 3 Disconnect the cold water line from the  $\frac{1}{2}$ " threaded stem on the bottom of the kitchen faucet. Attach threaded ends of supplied brass tee to the cold water supply line and shut-off valve; tighten using an adjustable wrench.
- 4 Attach  $\frac{1}{4}$ " white tube to the brass tee:

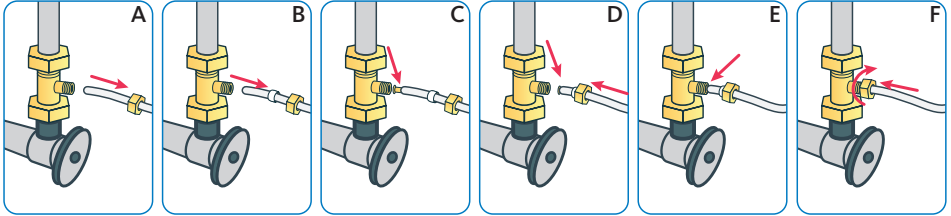

- A. Slide the compression nut onto the white tubing.
  - B. Slide the plastic sleeve onto the white tube.
  - C. Place brass insert into the opening of white tube.
  - D. Push the tip of the white tubing into the opening of the brass tee.
  - E. Slide the compression nut onto the threads of the brass tee.
  - F. While holding the white tube in place, tighten the compression nut to compress the plastic sleeve and create a seal. **NOTE: Use a wrench to ensure complete seal. Avoid over tightening.**
- 5 Do not connect the other end at this time.

## 3 — INSTALL WATER STORAGE TANK



- 1 On the nipple on top of the tank, apply plumber's tape 4 or 5 times clockwise around in the same direction as the threads.
- 2 Hand tighten the tank connector onto the tank nipple until secure. **NOTE: Do not cross thread or over tighten.**
- 3 Using mount stand, place tank near the system manifold. Measure  $\frac{3}{8}$ " white tubing to the outlet side of the system manifold and ensure you have enough tubing to connect tank and system manifold as well as enough left to attach faucet stem and remineralizer. Cut  $\frac{3}{8}$ " white tubing.

## 2 — INSTALL SYSTEM MANIFOLD

- 1 Select an easily accessible area under the sink to mount system manifold and remineralizer holder. You want to allow at least a 4 to 6 inch clearance below the filters to the floor to allow ample space for filter changes. To help gauge the right location for your system manifold, insert first and third stage filter sumps into manifold. Insert sumps by aligning top connection points and push up and to the right until sumps are locked in.

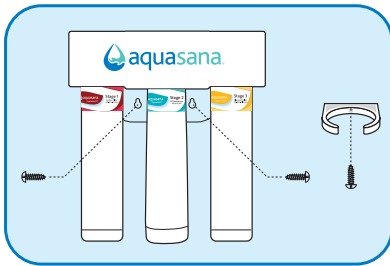
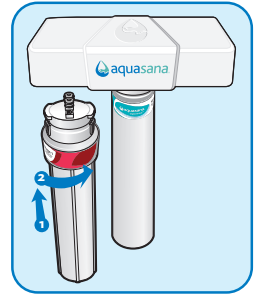

- 2 Mark wall placement for mounting screws using built-in bracket on back of manifold. Make sure holes are as level as possible. Mark screw placement of the remineralizer holder 1 or 2 inches from the third stage sump to the right of the manifold.

- 3 Drill two pilot holes for mounting brackets using  $\frac{1}{8}$ " drill bit for the system manifold. **NOTE: Use caution not to drill into anything beyond the cabinet wall.**

- 4 Insert mounting screws into the wall leaving approximately  $\frac{3}{8}$ " of each screw exposed.

- 5 Remove first and third filter sumps from manifold by turning each sump to the left and pulling down before hanging manifold on wall. Mount manifold on wall and screw in. Be careful not to over tighten.

- 6 Screw in remineralizer holder onto wall.

- 4 Install the  $\frac{3}{8}$ " white tubing to the tank:

- A. Push the tubing through the nut, collar and sleeve into the connector.
- B. Unscrew the compression nut from the tank connector to ensure that the tubing is connected all the way through the collar and sleeve.
- C. Slide the nut to the threads and tighten with a wrench. Avoid over tightening.

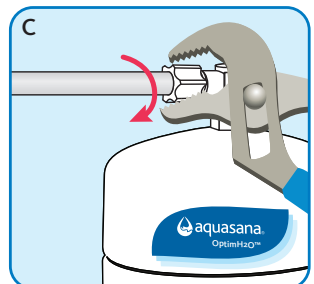
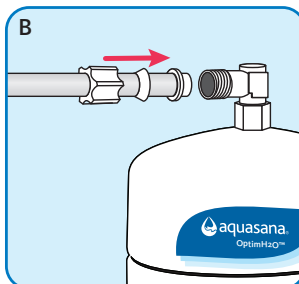
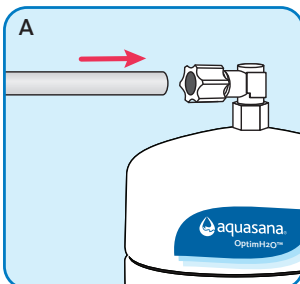

## 4 — INSTALL RO FAUCET

You will need a sink top hole 1" in diameter. If drilling a new hole, ensure faucet body will mount flat against surface and that there is sufficient tubing between faucet body and system manifold. **NOTE:** Drilling holes into solid surfaces or surfaces made of stone should only be performed by a qualified and certified installer.

- 1 Place the black rubber gasket into the groove of the faucet base and feed the tubing and faucet threads through the countertop hole.
- 2 Underneath counter, slide on the slotted washer, spacer and nut. Tighten with wrench.
- 3 Tighten the white quick connector onto the base of the faucet threads.
- 4 Attach  $\frac{3}{8}$ " white tubing by inserting into quick connector approximately  $\frac{5}{8}$ " until it stops. Gently tug on the tubing to ensure it is firmly seated in fitting.

**NOTE:** Do not connect  $\frac{3}{8}$ " white tubing from tank to faucet.

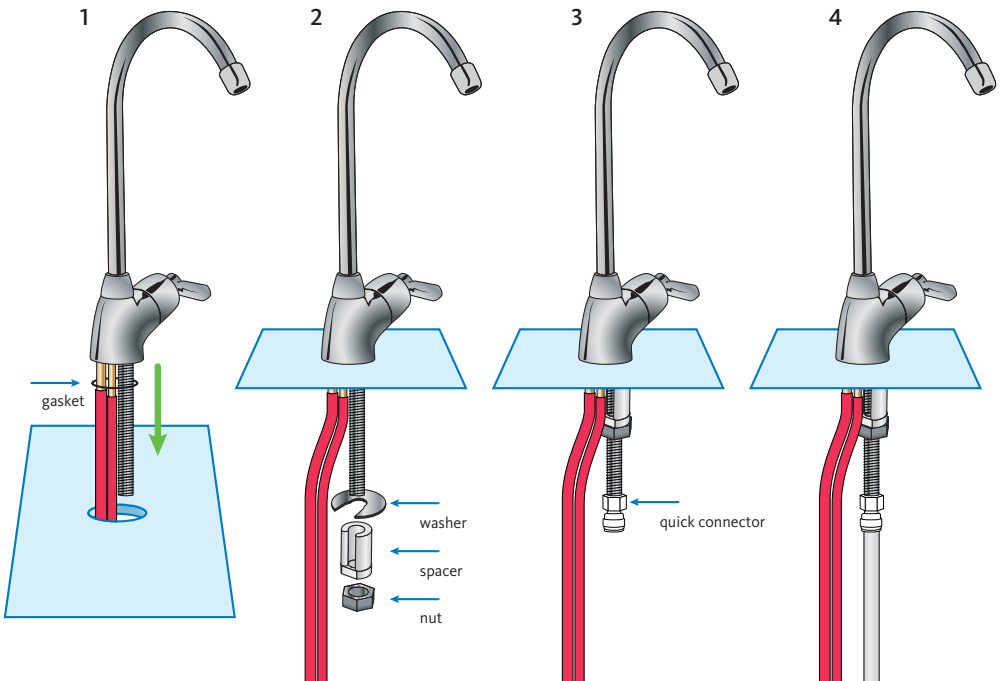

## 5 — INSTALL RO DRAIN CONNECTOR



### ⚠ WARNING

Be sure that all electrical appliances and outlets are turned off at the circuit breaker before working in the cabinet area.



### ⚠ CAUTION

Please wear safety glasses to protect eyes when drilling.

- 1 Identify drain outlet location. Do not install the drain connector onto the same drain pipe as the garbage disposal. If drain-line must be installed on the same line as a garbage disposal, do not use the drain connector included. A garbage disposal connector is recommended.
- 2 Remove protective cover from back of foam seal.
- 3 Knock center hole out, align holes, and attach to front plate of drain connector.
- 4 Allowing room for drilling, position the drain connector on sink drain pipe above drain trap.
- 5 Securely tighten nuts and screws.
- 6 Using the drain connector port as a drill guide, drill a  $\frac{7}{32}$ " hole into the drain pipe. Be sure not to penetrate opposite side of pipe, or to damage side of the drain port fitting.

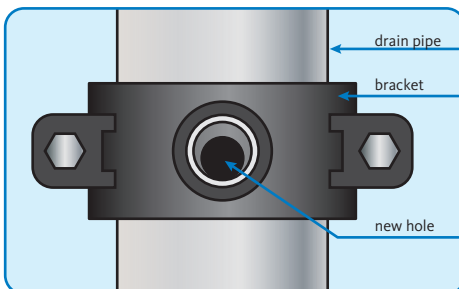
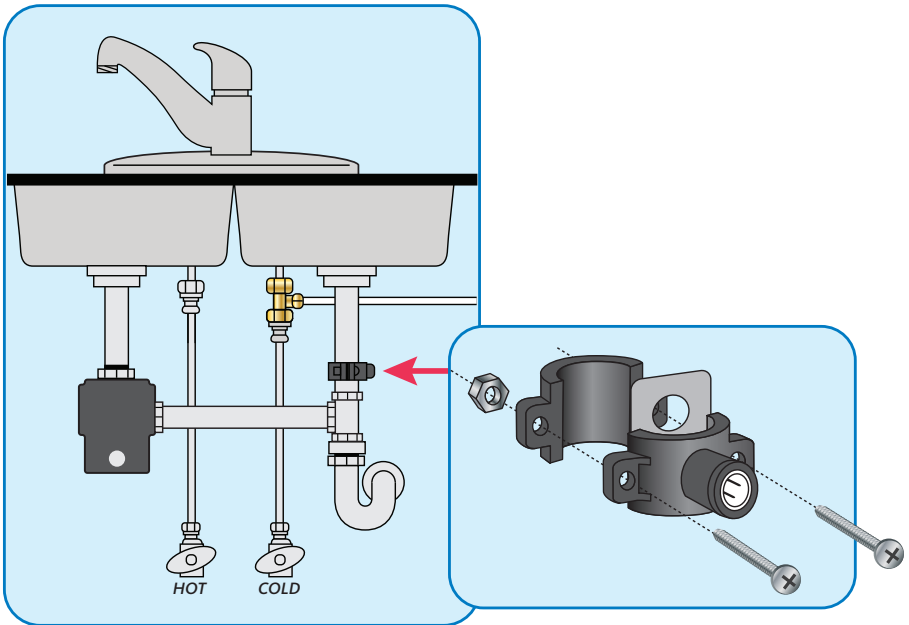

### Pro Tip

*If there is leakage from the drain bracket, loosen the bolts and slide the bracket up so the drilled hole is at the bottom of the drain connector port.*

## 6 — CONNECT TUBING

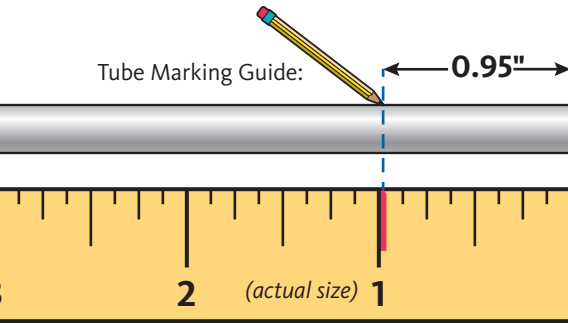

### Tubing Do's

*Insert tubing ALL THE WAY IN to prevent leaking. In most cases, up to nearly a full inch.*

*Wet end of tubing to more easily insert into all inlets and outlets.*

*Cut excess tubing in order to prevent crimping, kinks, loops or folds.*

### Tubing Don't's

*DO NOT cut tubing too short. Always double check measurements before cutting.*

*DO NOT bend or crimp or kink tubing.*

*DO NOT discard excess tubing.*

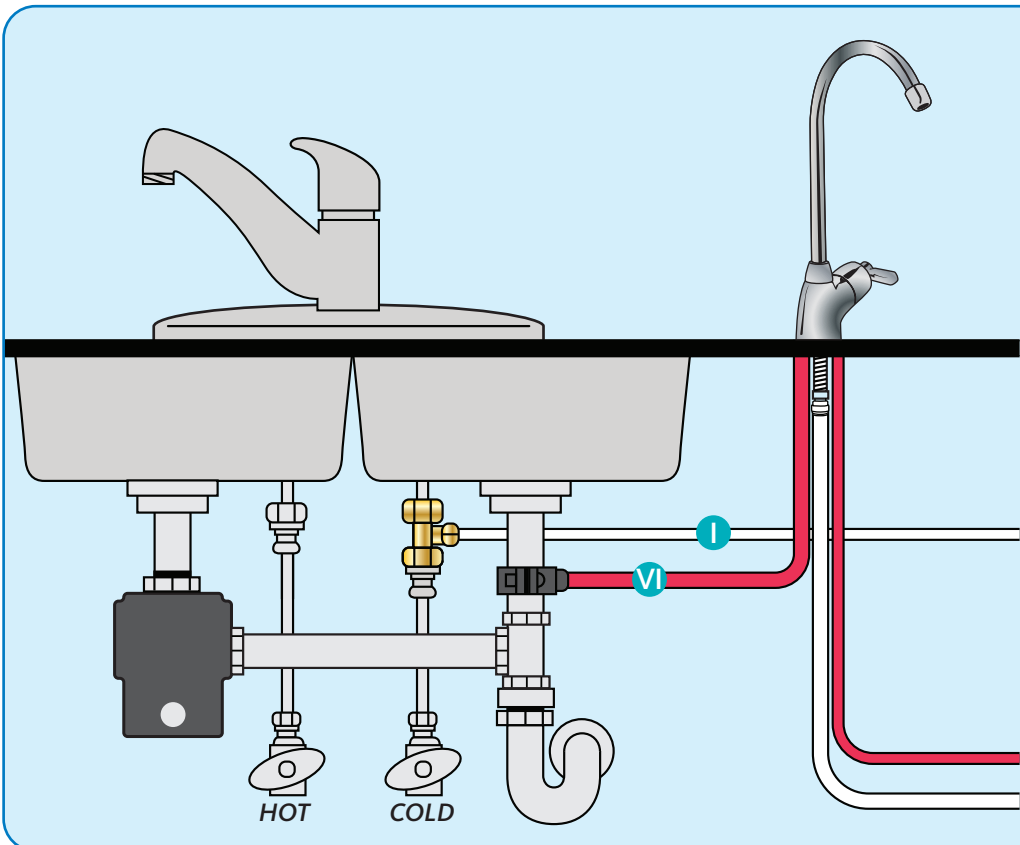



**I: Brass Tee to Manifold "INLET"** (¼" white tubing)

- 1 Take the white tubing leading from the brass tee and insert it into the manifold port labeled "INLET". Remember to push it all the way in until it stops.

**II: Manifold to Remineralizer** (⅜" red tubing included in packaging)

- 1 Insert one end into the manifold port labeled "FAUCET".
- 2 Insert the other end into the remineralizer port labeled "INLET".

**III: Remineralizer to Faucet** (⅜" white tubing already attached to faucet)

- 1 Insert the ⅜" white tubing (that was installed in step 4) from the faucet into the remineralizer port labeled "OUTLET".

**IV: Manifold to Tank** (⅜" white tubing already attached to tank)

- 1 Take the white tubing leading from the storage tank and insert it into the manifold port labeled "TANK". Remember to push it all the way in until it stops.

**V: Air Gap to RO Membrane** (¼" red tubing from faucet)

- 1 Insert restrictor into the end of the red tubing.
- 2 Attach ¼" red tubing to the 90° elbow until it stops.
- 3 Attach ¼" 90° elbow to the membrane drain port.

**VI: Faucet to Drain Connector** (⅜" red tubing from faucet)

- 1 Take the ⅜" red tubing from faucet and insert it all the way into the drain connector.

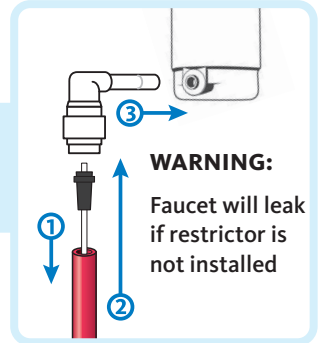

**Hose Connections:**

- |                     |                           |                    |                           |
|---------------------|---------------------------|--------------------|---------------------------|
| <b>I</b> ¼" White   | Brass Tee to Manifold     | <b>IV</b> ⅜" White | Manifold to Tank          |
| <b>II</b> ⅜" Red    | Manifold to Remineralizer | <b>V</b> ¼" Red    | Membrane to Faucet        |
| <b>III</b> ⅜" White | Remineralizer to Faucet   | <b>VI</b> ⅜" Red   | Faucet to Drain Connector |

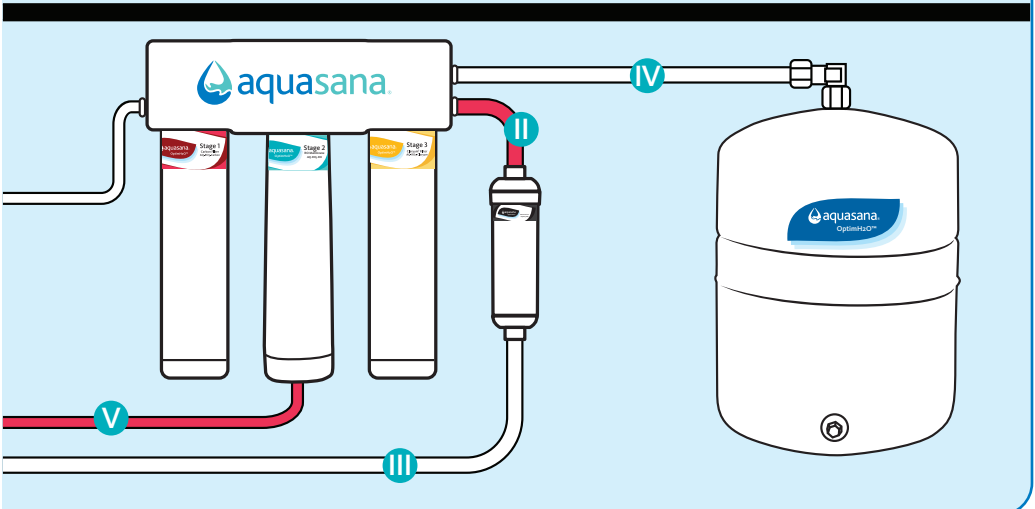

## 7 — STEP 1-3 FILTER INSTALLATION

*Before you begin: make sure the cold water valve is shut off and there is no pressure in the system. Carbon (red) and Claryum (yellow) filter cartridges will come pre-installed in their cartridge sumps.*

- 1 Attach red carbon sump to the 1st stage position on the inlet side of the system manifold. Make sure all connection points are aligned and push the top of the sump up and into the system manifold. Turn it towards the right until it locks in.
- 2 Repeat step 1 for the 2nd Stage RO membrane that goes in the center, and for the yellow Claryum cartridge in the 3rd stage position on the outlet side of the system manifold.

*Be sure to turn 2nd stage RO membrane all the way to the right, until drain port on cartridge is facing the rear of the system.*

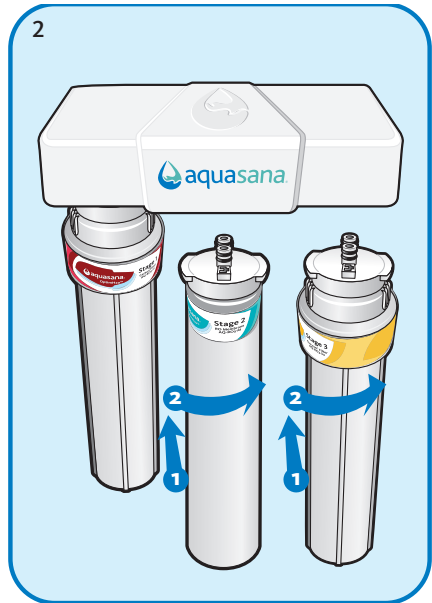
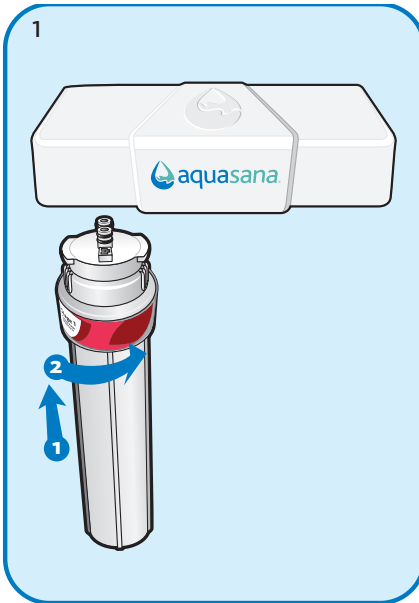

## 8 — SANITIZE, TEST & PURGE

### Sanitize

*Note: Sanitization is recommended immediately after RO Filter System installation and any inner-part servicing. The person sanitizing should have clean hands during this process.*

- 1 Shut off water supply to RO system.
- 2 Open faucet. If tank is not empty, allow to drain until empty.
- 3 With included eyedropper and household bleach (5.25%), disconnect white tubing from the manifold outlet labeled "TANK".  
**Note: Bleach needs to be handled according to manufacturer's instructions.**
- 4 Add 3ml bleach into open end of tank white tubing.
- 5 Reconnect the tank from the tube into the manifold outlet labeled "TANK". Be sure to push tubing in all the way.
- 6 Sanitization will be completed during the following pressure test and purge. Important: Bleach must be completely removed from system before drinking water. See Purge instructions below.

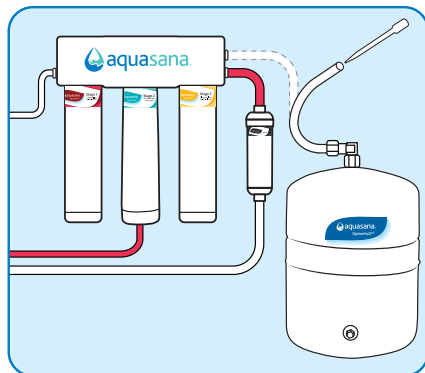

### Pressure Test

*Important: Complete sanitization prior to pressure test.*

- 1 Open cold water supply valve to RO Filter System.
- 2 To purge air from the plumbing system, open kitchen faucet. Close faucet when water runs smooth.
- 3 Confirm RO faucet is closed.
- 4 Within approximately 2 hours, pressure will start to build in the RO Filter System. Carefully inspect all connections and fittings while this pressure buildup occurs.
- 5 Check for leaks. If leaks are found, fix by ensuring all tubing is cut squarely and fully inserted. Also confirm there are no scratches, dents or notches at tubing end. If there are, squarely cut 1" off and re-insert.

*Note: When RO Filter System is first pressurized, water may project from faucet air gap hole until air is passed from RO Filter System.*

### Purge

- 1 Open RO faucet and let water flow through system for 24 hours.  
*Note: Flow rate will be slow during this time.*

- 2 Close RO faucet after purge is complete.

*Note: Your RO Filter System is ready for use when purge is complete, however, you will not have filtered water immediately. It takes 1-3 hours to completely fill the tank. The flow rate will be less than your kitchen faucet. Water will run to the drain while the RO Filter System is filtering water – even when not in use. This is normal. Water going to drain will stop automatically when tank is at capacity.*

### 3-STAGE RO SYSTEM – MODEL AQ-RO-3

	<b>U.S.</b>	<b>Metric</b>
Membrane Production <sup>1</sup>	35 gpd	132 lpd
Membrane TDS Reduction <sup>1</sup>	95% minimum	95% minimum
System Production <sup>2</sup>	13.32 gpd	50.4 lpd
TDS Reduction <sup>2</sup>	96.3%+ average	96.3%+ average
Maximum TDS	1000 ppm	1000 ppm
Maximum water hardness @ 6.9pH	10 gpg	2.64 gpl
Maximum Chlorine in water	3.0 ppm	3.0 ppm
Supply water pH limits	4-10	4-10
Drain (reject water) Flow	3-5 x product flow	3-5 x product flow
Empty Storage Tank Precharge	5-7 psi air	35-48 kPa air
Storage Tank Capacity <sup>2</sup>	3.2 gallons	12.11 liters
Supply water pressure limits	40-100 psi	275-689 kPa
Supply water temperature limit	40-100° F	5-37° C
Efficiency <sup>3</sup>	17.91%	17.91%
Recovery <sup>4</sup>	29.43%	29.43%

### Capacity at various water pressure levels (with 5 psi precharge) U.S. Gallons

<b>Total Volume</b>	<b>20 psi</b>	<b>30 psi</b>	<b>40 psi</b>	<b>50 psi</b>	<b>60 psi</b>	<b>70 psi</b>
3.2	1.4	1.8	2.0	2.2	2.4	2.5

## Specifications – Qualified System Performance

Because the performance of a Reverse Osmosis Membrane is highly dependent upon pressure, temperature and TDS, the following should be used for comparison purposes only.

- 1 Industry standards measure RO Membranes performance with no back pressure on the product water, at 60 psig (414kPa) and 77°F (25°C). Further conditions on the above are 250 ppm TDS and a 30.6% recovery rate. Production rate and TDS reduction figures are for a new Membrane that has been rinsed for 24 hours. The production rate of a new Membrane can decrease by 10% per year or more, depending upon the scaling and fouling tendencies of the Feed Water.
- 2 Measured at 50 psi, 77°±2°F, and 717 mg/l TDS per NSF/ANSI Standard 58.
- 3 Efficiency rating means the percentage of the influent water to the system that is available to the user as reverse osmosis treated water. Under operating conditions that approximate typical daily usage.
- 4 Recovery rating means the percentage of the influent water to the membrane portion of the system that is available to the user as reverse osmosis treated water when the system is operated without a storage tank or when the storage tank is bypassed.



**Do not use with water that is microbiologically unsafe or of unknown water quality without adequate disinfection before or after the system. Systems certified for cyst reduction may be used on disinfected waters that may contain filterable cysts.**



**Filter is only to be used with cold water. Systems certified for cyst reduction may be used on disinfected water that may contain filterable cysts.**

## Non-potable Water Sources:

Do not attempt to use this product to make safe drinking water from non-potable water sources. Do not use the system on microbiologically unsafe water, or water of unknown quality without adequate disinfection before or after the system. This system is certified for cyst reduction and may be used on disinfected water that may contain filterable cysts.

## Installations in The Commonwealth of Massachusetts:

The Commonwealth of Massachusetts requires installation be performed by a licensed plumber and do not permit the use of saddle valves. Plumbing code 248—CMR of the Commonwealth of Massachusetts must be followed in these cases.

## **Nitrate/Nitrite Test Kit:**

This system is acceptable for treatment of influent concentration of no more than 27mg/L nitrate and 3mg/L nitrite in combination measured as N.\* This system is supplied with a nitrate/nitrite test kit. Product water should be monitored periodically according to the instructions provided with the test kit.

## **Drain Flow Restrictor**

The restrictor is vital for proper operation of the RO membrane cartridge as it keeps water flowing through the membrane at the proper rate ensuring the water produced is the best quality. It is recommended the restrictor assembly be periodically inspected to be sure it is clean and unrestricted. If service is required on the drain flow assembly, disassemble and reassemble as outlined in Step Six.

## **Flow rate and output are determined by 3 factors:**

- 1** Incoming water temperature
- 2** Total dissolved solids (TDS) present in supply water
- 3** Incoming water pressure

Lower temperatures are directly proportional to slower flow rate. All membranes are tested at 77°F. Incoming water temperature should not exceed 100°F. The RO Filter System should also not be installed in a location susceptible to freezing. The more TDS in the supply water, greater filter time is required. Incoming TDS should not exceed 1000 ppm. Higher water pressure enables a higher flow rate. Pressure must be above 40 psi for proper system operation. You may consider installing a booster pump if your pressure is below 40 psi.

## **Carbon Pre-Filter & Claryum® Post-Filter - *Change every 6 months\****

The carbon and Claryum filter cartridges are replaceable activated carbon cartridges located in stages 1 and 3. It is recommended replacing these cartridges at least every 6 months. You may need to replace more often with high water usage or high sediment level. Replacing these cartridges timely will protect the RO membrane from high levels of chlorine and/or sediment. As these filters build up with sediment, you may notice slower water output.

## **RO Membrane Cartridge - *Change every 12 months***

The RO membrane is located in stage 2. This membrane reduces the dissolved solids and organic matter. Most municipally treated water has a 7.0-7.5 pH, in this case you would need to replace your RO membrane every 12 months. Membrane life depends on pH and supply water hardness. Higher pH shortens membrane life by causing pin-hole leaks, and would shorten membrane life. When output and water quality and production rate decrease, it is time to replace the filter sump.

## **Remineralizer - *Change every 12 months\****

**Important:** For the first 36 hours after the initial installation, make sure to periodically inspect for leaks while the system is running and while it is turned off. If a leak occurs, shut off the water supply, open up the filter faucet to release pressure from the system & contact Aquasana Technical Support 866.662.6885.

If you are adding the remineralizer to a system that has already been installed, shut off the filter faucet, turn on the water supply and allow the RO tank to fill up completely. Once the tank is completely filled, flush & saturate the remineralizer cartridge by opening up the filter faucet and allowing the purified water to run through the remineralizer for 3 minutes. The water may come out cloudy during the initial flush.

*\*Filter life depends on water usage and water supply quality.*

*Faucet is not part of NSF Certification*



Performance Data for the OptimH2O™ Drinking Water System: Model AQ-RO-3					
Replacement	Operating pressure range	Operating temp range	Recovery Rating	Efficiency Rating	Daily Production (DPR)
AQ-RO3-RO, AQ-RO3-Carbon, AQ-RO3-Claryum	40-100 psi 275-689 kPa	40-90° F 4.44-32.2° C	29.43%	17.91%	13.32 gallons 50.4 liters
Manufactured by: AquaSana, Inc. 6310 Midway Road - Haltom City, Texas 76117 - 866.662.6885					

Testing Performed under NSF/ANSI Standards 42 and 53 and in accordance with the California Department of Health Services Drinking Water Treatment Device Program. This system has been tested according to NSF/ANSI 42, 53, 58, 401 & P473 for reduction of the substances listed below. The concentration of the indicated substances in water entering the system was reduced to a concentration less than or equal to the permissible limit for water leaving the system, as specified in NSF/ANSI 42, 53, 58, 401 & P473.

NSF/ANSI 42	Minimum reduction	Overall % reduction	Results
Chlorine Reduction, Free Available	<0.5 mg/l	97.66%	Pass
Chloramine Reduction, Free Available	<0.5 mg/l	97.66%	Pass
Particulate Reduction	85%	99.9%	Pass

NSF/ANSI 53	Required reduction	Overall % reduction	Results
Cyst Live Cryptosporidium & Giardia	99.95%	>99.99%	Pass
Mercury Reduction pH 8.5	<2 ug/L	>95.8%	Pass
Mercury Reduction pH 6.5	<2 ug/L	>96.5%	Pass
Lead Reduction pH 6.5	<10 ug/L	>99.4%	Pass
Lead Reduction pH 8.5	<10 ug/L	>99.3%	Pass
MTBE Reduction	<5 ug/L	86.6%	Pass
Turbidity	<0.5 NTU	99.1%	Pass
VOC Surrogate Test	95%	99.4%	Pass
Asbestos Reduction	99%	>99%	Pass

NSF/ANSI 58	Maximum Concentration	Minimum Reduction	Overall % Reduction	Results
Arsenic Pentavalent	0.30 <sup>mg/L</sup> ±10%	80.0%	97.6%	Pass
Barium	10.0 <sup>mg/L</sup> ±10%	80.0%	95.2%	Pass
Cadmium	0.30 <sup>mg/L</sup> ±10%	83.3%	95.3%	Pass
Chromium Hexavalent	0.30 <sup>mg/L</sup> ±10%	66.7%	97.0%	Pass
Chromium Trivalent	0.30 <sup>mg/L</sup> ±10%	66.7%	96.6%	Pass
Copper	0.30 <sup>mg/L</sup> ±10%	56.7%	96.6%	Pass
Fluoride	8.0 <sup>mg/L</sup> ±10%	81.2%	95.7%	Pass
Lead	0.15 <sup>mg/L</sup> ±10%	93.3%	96.6%	Pass
Nitrate/Nitrite	30.0 <sup>mg/L</sup> ±10%	66.70%	82.40%	Pass
Radium 226/228	25 <sup>pCi/L</sup> ±10%	80.0%	80.0%	Pass
Selenium	0.10 <sup>mg/L</sup> ±10%	50.0%	97.9%	Pass
TDS	750 <sup>mg/L</sup> ±10%	75.0%	95.0%	Pass
Turbidity	11 ± NTU	95.4%	99.1%	Pass

NSF/ANSI 401	Maximum Concentration	Minimum Reduction	Overall % Reduction	Results
Atenolol	30 ng/L	94.2%	94.2%	Pass
Bisphenol A	300 ng/L	98.80%	98.9%	Pass
Carbamazepine	200 ng/L	98.6%	98.6%	Pass
DEET	200 ng/L	98.7%	98.7%	Pass
Estrone	20 ng/L	96.30%	96.5%	Pass
Ibuprofen	60 ng/L	95.3%	95.4%	Pass
Linuron	20 ng/L	96.6%	96.6%	Pass
Meprobamate	60 ng/L	94.7%	94.7%	Pass
Metolachlor	200 ng/L	98.6%	98.6%	Pass
Naproxen	20 ng/L	96.3%	96.4%	Pass
Nonyl phenol	200 ng/L	97.50%	97.5%	Pass
Phenytol	30 ng/L	95.50%	95.6%	Pass
TCEP	700 ng/L	98%	98%	Pass
TCPP	700 ng/L	97.8%	97.8%	Pass
Trimethoprim	20 ng/L	96.7%	96.7%	Pass

NSF P473	Influent challenge concentration	Maximum permissible product water concentration	Overall % reduction	Results
Perfluorooctanoic acid (PFOA) & Perfluorooctane sulfonate (PFOS)	1.5 ±10% ug/L	0.07 ug/L	96%	Pass



Do not use with water that is microbiologically unsafe or of unknown water quality without adequate disinfection before or after the system.

Organic chemicals included by surrogate testing

VOCs (by surrogate testing using chloroform)	Drinking water regulatory level (MCL/MAC) mg/L	Influent/ Unfiltered	Effluent/ Filtered	Percent Reduction
alachlor	0.002	0.050	0.001	>98%
atrazine	0.003	0.100	0.003	>97%
benzene	0.005	0.081	0.001	>99%
carbofuran	0.04	0.190	0.001	>99%
carbon tetrachloride	0.005	0.078	0.0018	98%
chlorobenzene	0.1	0.077	0.001	>99%
chloropicrin	—	0.015	0.0002	99%
2,4-D	0.07	0.110	0.0017	98%
dibromochloropropane (DBCP)	0.0002	0.052	0.00002	>99%
o-dichlorobenzene	0.6	0.080	0.001	>99%
p-dichlorobenzene	0.075	0.040	0.001	>98%
1,2-dichloroethane	0.005	0.088	0.0048	95%
1,1-dichloroethylene	0.007	0.083	0.001	>99%
cis-1,2-dichloroethylene	0.07	0.170	0.0005	>99%
trans-1,2-dichloroethylene	0.1	0.086	0.001	>99%
1,2-dichloropropane	0.005	0.080	0.001	>99%
cis-1,3-dichloropropylene	—	0.079	0.001	>99%
dinoseb	0.007	0.170	0.0002	99%
endrin	0.002	0.053	0.00059	99%
ethylbenzene	0.7	0.088	0.001	>99%
ethylene dibromide (EDB)	0.00005	0.044	0.00002	>99%
haloacetonitriles (HAN)				
Bromochloroacetonitrile	—	0.022	0.0005	98%
Dibromoacetonitrile	—	0.024	0.0006	98%
Dichloroacetonitrile	—	0.0096	0.0002	98%
Trichloroacetonitrile	—	0.015	0.0003	98%
haloketones (HK)				
1,1-dichloro-2-propanone	—	0.0072	0.0001	99%
1,1,1-trichloro-2-propanone	—	0.0082	0.0003	96%
heptachlor (H-34, Heptox)	0.0004	0.025	0.00001	>99%
heptachlor epoxide	0.0002	0.0107	0.0002	98%
hexachlorobutadiene	—	0.044	0.001	>98%
hexachlorocyclopentadiene	0.05	0.060	0.000002	>99%
lindane	0.0002	0.055	0.00001	>99%
methoxychlor	0.04	0.050	0.0001	>99%
pentachlorophenol	0.001	0.096	0.001	>99%
simazine	0.004	0.120	0.004	>97%
styrene	0.1	0.150	0.0005	>99%
1,1,2,2-tetrachloroethane	—	0.081	0.001	>99%
tetrachloroethylene	0.005	0.081	0.001	>99%
toluene	1	0.078	0.001	>99%
2,4,5-TP (silvex)	0.05	0.270	0.0016	99%
tribromoacetic acid	—	0.042	0.001	>98%
1,2,4-trichlorobenzene	0.07	0.160	0.0005	>99%
1,1,1-trichloroethane	0.2	0.084	0.0046	95%
1,1,2-trichloroethane	0.005	0.150	0.0005	>99%
trichloroethylene	0.005	0.180	0.0010	>99%
Trihalomethanes (THMs)				
Bromodichloromethane (THM)	0.080	0.300	0.015	95%
Bromoform (THM)				
Chloroform (THM)				
Chlorodibromomethane (THM)				
Xylenes (total)	10	0.070	0.001	>99%



The AQ-RO3 has been tested and certified by NSF International against NSF/ANSI Standards 42, 53 and 401 in model AQ-RO-3 for the reduction claims specified on the Performance Data Sheet as verified and substantiated by test data and at nsf.org.



The AQ-RO-3 has been tested and certified by NSF International against NSF/ANSI Standard 58 for the reduction claims specified on the Performance Data Sheet as verified and substantiated by test data and at nsf.org.



This system has been tested for the treatment of water containing pentavalent arsenic (also known as As(V), As(+5), or arsenate) at concentrations of 0.30 mg/L or less. This system reduces pentavalent arsenic, but may not remove other forms of arsenic. This system is to be used on water supplies containing a detectable free chlorine residual at the system inlet or on water supplies that have been demonstrated to contain only pentavalent arsenic. Treatment with chloramine (combined chlorine) is not sufficient to ensure complete conversion of trivalent arsenic to pentavalent arsenic. Please see the **Arsenic Facts** section of this Performance Data Sheet for further information.

## Arsenic Facts

Arsenic (abbreviated As) is found naturally in some well water. Arsenic in water has no color, taste, or odor. It must be measured by a laboratory test.

Public water utilities must have their water tested for arsenic. You can get the results from your water utility. If you have your own well, you can have the water tested. The local health department or the state environmental health agency can provide a list of certified labs. The cost is typically \$15 to \$30. Information about arsenic in water can be found on the Internet at the U.S. Environmental Protection Agency website: [epa.gov/safewater/arsenic.html](http://epa.gov/safewater/arsenic.html).

There are two forms of arsenic: **pentavalent arsenic** As(V), As(+5), and arsenate) and **trivalent arsenic** (also called As(III), As(+3), and arsenite). In well water, arsenic may be pentavalent, trivalent, or

a combination of both. Special sampling procedures are needed for a lab to determine what type and how much of each type of arsenic is in the water. Check with the labs in your area to see if they can provide this type of service. Reverse osmosis (RO) water treatment systems do not remove trivalent arsenic from water very well. RO systems are very effective at removing pentavalent arsenic. A free chlorine residual will rapidly convert trivalent arsenic to pentavalent arsenic. Other water treatment chemicals such as ozone and potassium permanganate will also change trivalent arsenic to pentavalent arsenic. A combined chlorine residual (also called chloramine) may not convert all the trivalent arsenic. If you get your water from a public water utility, contact the utility to find out if free chlorine or combined chlorine is used in the water system. The

AQ-RO-3 system is designed to remove pentavalent arsenic. It will not convert trivalent arsenic to pentavalent arsenic. The system was tested in a lab. Under testing conditions, the system reduced [0.30 mg/L (ppm) or 0.050 mg/L (ppm)] pentavalent arsenic to 0.010 mg/L (ppm) (the USEPA standard for drinking water) or less. The performance of the system may be different at your installation.

Have the treated water tested for arsenic to check whether the system is working properly. The RO component of the AQ-RO-3 system must be replaced every 1-3 years to ensure that the system will continue to remove pentavalent arsenic. The component identification and locations where you can purchase the component are listed in the installation/operation manual.



Filter is only to be used with cold water.



Filter usage must comply with all state and local laws.



Testing was performed under standard laboratory conditions, actual performance may vary.



Systems certified for cyst reduction may be used on disinfected waters that may contain filterable cysts.



See owner's manual for general installation conditions and needs plus manufacturer's limited warranty.

- All contaminants reduced by this filter are listed.
- Not all contaminants listed may be present in your water.
- Filter does not remove all contaminants that may be present in tap water.

- **Efficiency rating** means the percentage of the influent water to the system that is available to the user as reverse osmosis treated water under operating conditions that approximate typical daily usage.
- **Recovery rating** means the percentage of the influent water to the membrane portion of the system that is available to the user as reverse osmosis treated water when the system is operated without a storage tank or when the storage tank is bypassed.

**2****YEAR  
LIMITED  
WARRANTY****AQ-RO-3 OPTIMH2O® REVERSE OSMOSIS + CLARYUM®  
2-YEAR LIMITED WARRANTY****What is covered**

This Warranty covers defects in materials or workmanship in manufacturing of the Aquasana OptimH2O® Reverse Osmosis + Claryum®, except as provided below.

**For how long**

This warranty runs for 24 months from the date of purchase by a consumer "Warranty Period".

**What is not covered**

This warranty does not cover filter cartridges and any products that were not installed in compliance with the instructions or that have been abused or operated incorrectly. It also does not cover incidental or consequential damages caused by a failure of the product.

Finally, this warranty is voided if the product is used with parts that are not genuine Aquasana parts. This includes, but is not limited to: replacement filters, faucets, and diverter valves.

This warranty does not cover the RHINO Whole House Filtration System.

**What Aquasana will do**

We will replace the defective part of the covered product and send it to you with installation instructions upon payment for shipping and handling per incident.

**How to get service**

To receive service under this Warranty, you must contact Aquasana, Inc. at 1-866-662-6885 or [warranty@aquasana.com](mailto:warranty@aquasana.com) within the Warranty Period to describe the problem to a customer service representative who will verify that the product is under warranty and arrange for delivery of a replacement part.

**How state law applies**

This warranty gives you specific rights and you may have other rights which vary from state to state. Some states do not allow the exclusion or limitation of incidental or consequential damages, so the above limitation or exclusion may not apply to you.

**Warranty Registration**

Warranty registration is not required for coverage under the Aquasana Limited Warranty and is not necessary for factory direct purchases made from [www.aquasana.com](http://www.aquasana.com). If you purchased from a retailer or dealer, please complete the online warranty registration form at [www.aquasana.com/warranty](http://www.aquasana.com/warranty). Once registered online, we will have a record of your purchase and you will not be required to produce a proof of purchase for a warranty claim.



water for life®

## Replace your filters on time, without worry — auto-delivered to you, for less.

It's important to change your filters using genuine Aquasana replacements for continued water filtration and optimum system performance. This is why we offer our no contract, auto-ship filter replacement program called Water for Life®.



### Free Shipping

Replacements shipped directly to you, right when you need them, at no extra cost.



### Discount Replacements

Lock in a 15% discount on filters to ensure you always get the best price.



### Extended Warranty

Our performance promise to you – free replacement parts, just in case.



### No Contract

Replacing your filters is serious – but your commitment doesn't have to be.

## CONTACT US TO LEARN MORE



866-662-6885



[waterforlife@aquasana.com](mailto:waterforlife@aquasana.com)



### LOVE IT?

Please let us know with a review on Aquasana or your retailer's website.



### NEED HELP?

Give us a call at 866-662-6885 and tell us what's going on.

**Aquasana, Inc.**  
6310 Midway Road  
Haltom City, Texas 76117  
866.662.6885 USA  
877.332.7873 Canada  
[www.aquasana.com](http://www.aquasana.com)